

## Printing and Cutting Overview

[\[Next\]](#)

### Overview

The basic flow of printing and cutting operations is as follows:

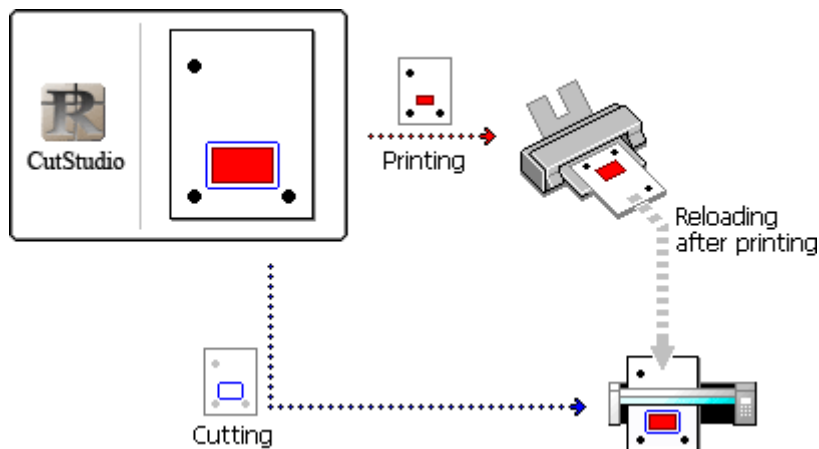

1. Create data containing image with crop marks and contour lines.
2. Print the data on the printer.
3. Load the printed material on the cutting machine.
4. Send the data from the computer to the cutting machine.
5. Detect the crop marks and start the cutting operation.

### Crop marks

Marks used for alignment when cutting the printed material on the cutting machine.  
The GX-24 detects only the following marks as crop marks.

Diameter: 10 mm

Color: Black (100% density)

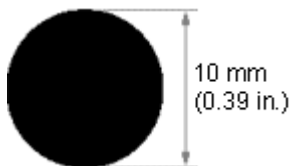
[\[Next\]](#)

# Using Crop Marks

[\[Back/Next\]](#)

● **The following conditions must be met to use crop marks on the GX-24.**

## Software used to create the data

The following software program is used.

### Roland CutStudio

Be sure to install this program.

The program is installed from the CD-ROM that comes with the GX-24.

Printing and cutting operations can be performed using only CutStudio.

For the installation procedure, see the **Roland GX-24 User's Manual** (printed manual).

### Adobe Illustrator 9/10/CS

To perform printing and cutting operations on Illustrator, the following software programs must be installed.

- **Roland CutStudio**
- **CutStudio Plug-in for Adobe Illustrator**

For the installation procedure, see the [CutStudio Plug-in for Adobe Illustrator/CorelDRAW Setup Guide](#) (electronic format manual).

Note that the plug-in can be installed only if Adobe Illustrator is installed.

## Printer

### A laser printer or inkjet printer with 720 dpi resolution or better

- The printed crop marks may not be read correctly depending on the printer ink.
- If the printed filled sections are blurred, crop marks will not be read correctly.

## Types of Material

Use the following types of material.

### Material with carrier paper that can be printed on a laser or inkjet printer

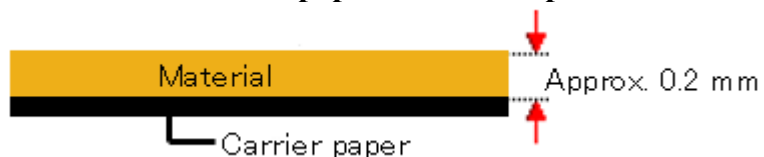

Material portion type	
<b>Laser printer</b>	Fine paper, coated paper, and PET (Polyethylene Terephthalate)
<b>Inkjet printer</b>	Fine paper and coated paper

- **Material-portion thickness:**Approx. 0.2 mm

- **Color:** White

Laminated and glossy materials cannot be used.

[\[Back/Next\]](#)

## Printing and Cutting (When Using CutStudio)

[\[Back/Next\]](#)

The image data is imported into CutStudio and cutting lines are drawn.  
This method uses CutStudio for printing and cutting.

- [Step 1: Create the data](#)
- [Step 2: Print the data](#)
- [Step 3: Load the printed material](#)
- [Step 4 :Perform cutting](#)

[\[Back/Next\]](#)

## Printing and Cutting (When Using CutStudio)

[\[Back/Next\]](#)

### Step 1: Create the data

1. Start **CutStudio**.
2. From the **File** menu, click **Cutting Setup**.  
The **Cutting Setup** dialog box opens.  
Select **Roland GX-24** for the **Name**.
3. From the **File** menu, click **Print & Cut**.  
The print range and crop marks are displayed on the screen.  
The print range is displayed with dotted lines. This range corresponds to the paper size specified in **Set up the printer** excluding the margins specified in **Printing Setup**.

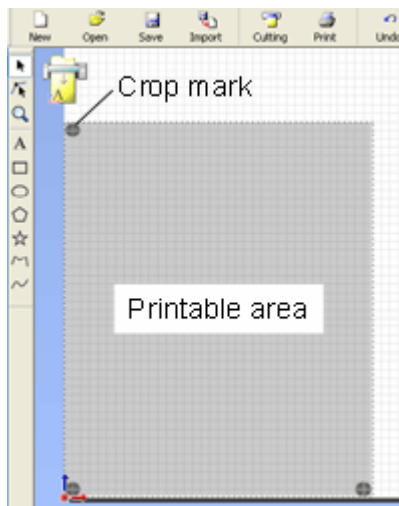

4. From the **File** menu, click **Set up the printer**.  
The **Print Setup** dialog box opens.  
Select the paper size and click **OK**.  
When expanded/reduced printing is enabled, disable it. Print at 100% scale.  
For details, see the instruction manual for your printer.
5. From the **File** menu, click **Printing Setup**.  
The **Printing Setup** dialog box opens.

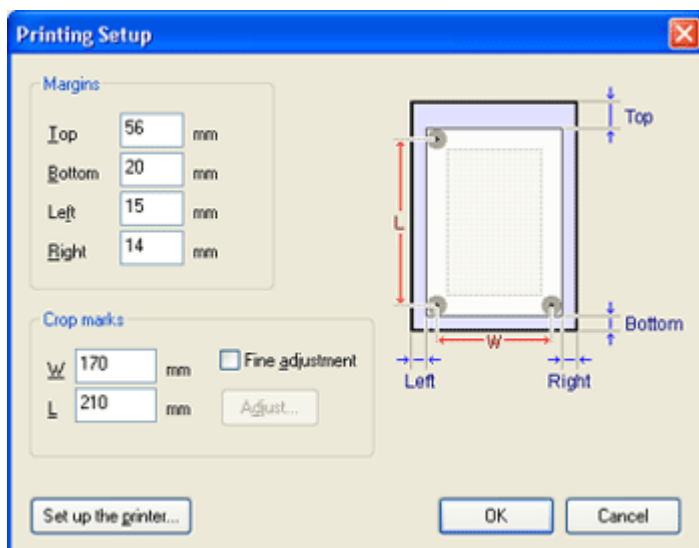

Set the margin and the distance between crop marks, and then click **OK**.  
 Take into account the margin necessary for cutting the material, and set the crop mark position.  
 When cutting with the GX-24, enter the following values.

Size	Margin and crop mark settings
A4 portrait	Top: 57 mm, Bottom: 20 mm, Left: 15 mm, Right: 15 mm W: 170 mm, L: 210 mm
A4 landscape	Top: 60 mm, Bottom: 20 mm, Left: 30 mm, Right: 17 mm W: 240 mm, L: 120 mm
A3 portrait	Top: 60 mm, Bottom: 20 mm, Left: 30 mm, Right: 17 mm W: 240 mm, L: 330 mm
A3 landscape	Top: 62 mm, Bottom: 20 mm, Left: 15 mm, Right: 15 mm W: 380 mm, L: 205 mm
B4 portrait	Top: 59 mm, Bottom: 20 mm, Left: 15 mm, Right: 17 mm W: 215 mm, L: 275 mm
B4 landscape	Top: 57 mm, Bottom: 20 mm, Left: 15 mm, Right: 14 mm W: 325 mm, L: 170 mm

\* If you are using a material of size larger than A4 that is not listed above, set the values by referring to the figure below.

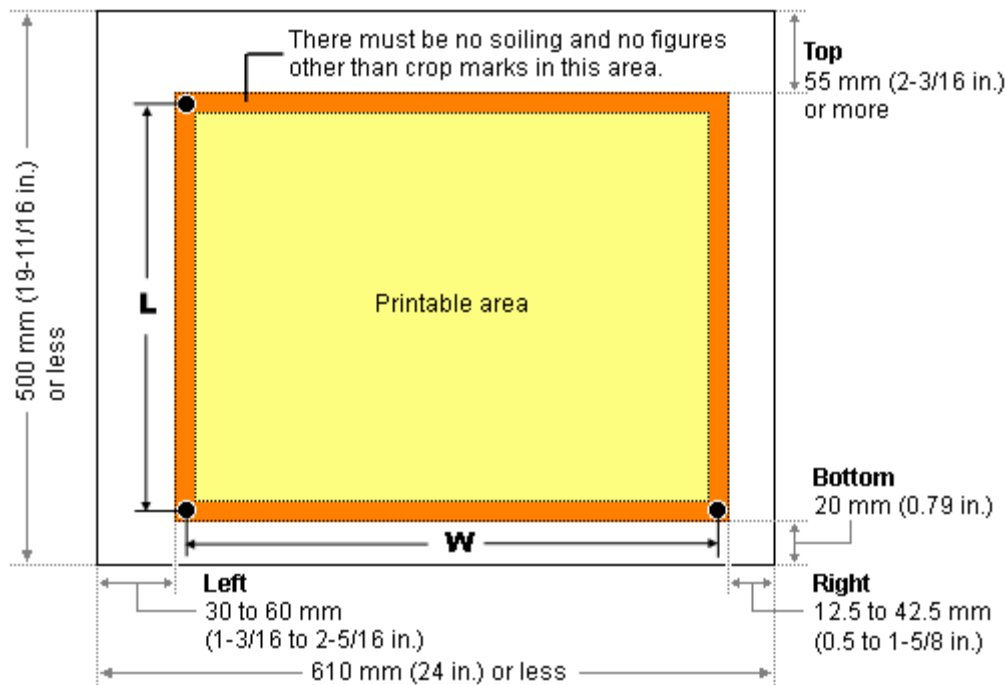

**Hint:** A bottom margin of 20 mm is adequate for all cases. It eliminates the hassle in loading the material.

**Reference:** [Load the printed material](#)

After setting the values, check that the crop marks are within the print range.

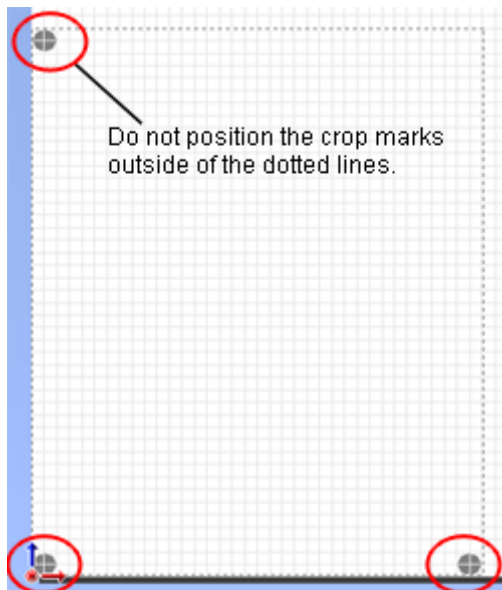

- Click  to import the image data you wish to print. The imported image is displayed lightly.

\* To change the density of the image display, open the **General** tab in the **Preferences** dialog box. For details, see "[**Preferences**] dialog box" in the CutStudio help.

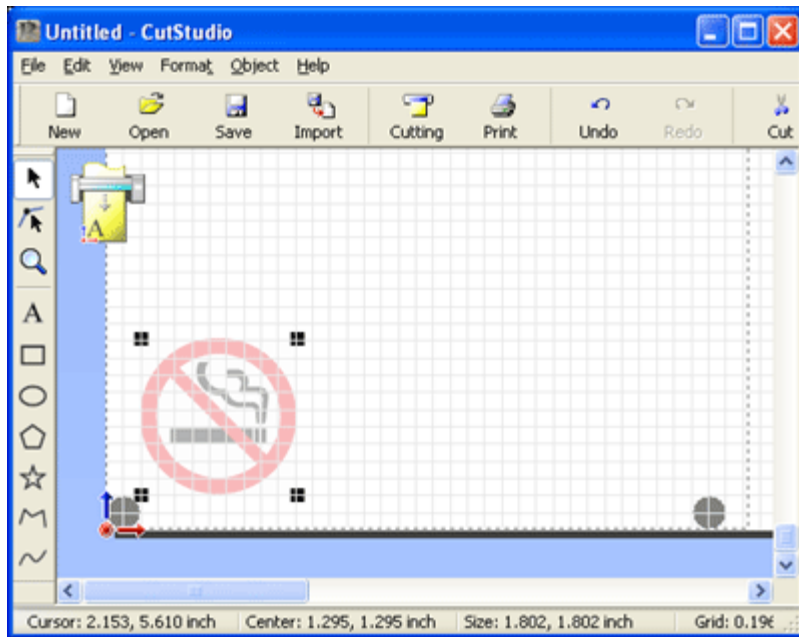

The file formats that CutStudio can import are as follows:

**JPEG and BMP formats**

However, JPEG images saved with CMYK cannot be imported.

7. Position the data in the area within the crop marks.

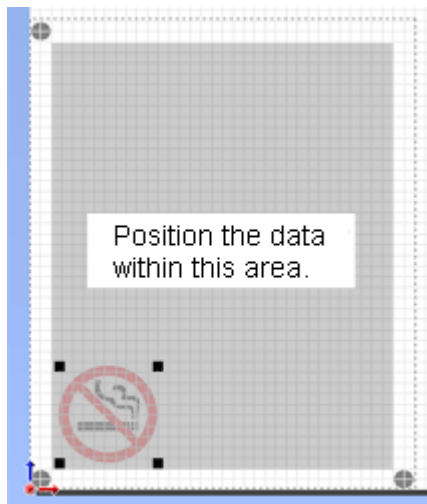

8. Draw the cutting lines.

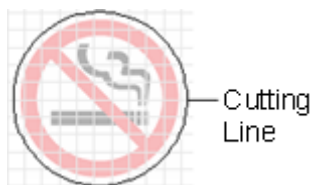

9. Save the data.

## Printing and Cutting (When Using CutStudio)

[\[Back/Next\]](#)

### Step 2: Print the data

1. Load the material to be cut in the printer.  
For details on how to load the material, see the instruction manual for your printer.

2. Click .  
The **Print** dialog box opens.

3. Click **OK**.  
The image data with crop marks is printed.  
The cutting lines drawn with CutStudio are not printed.

[\[Back/Next\]](#)

## Printing and Cutting (When Using CutStudio)

[\[Back/Next\]](#)

### Step 3: Load the printed material

1. Pass the material through the machine and move the pinch rollers as shown in the figure.
  - Position the pinch rollers outside the crop marks.
  - Be sure that both edges of the material and the pinch rollers are inside the pinch-roller position-verification marks.

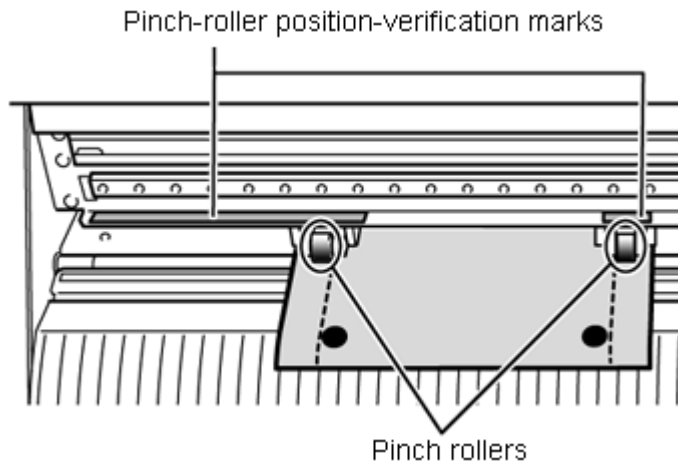

- Align the three crop marks as shown in the figure. If the material is loaded in the wrong direction, the GX-24 cannot read the crop marks.



2. Align the left edge of the material so that it lies parallel to the guide line.

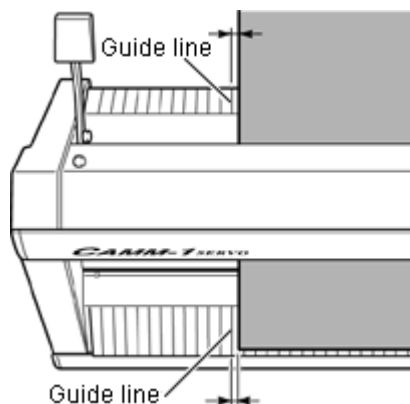

3. Raise the loading lever to secure the material in place.

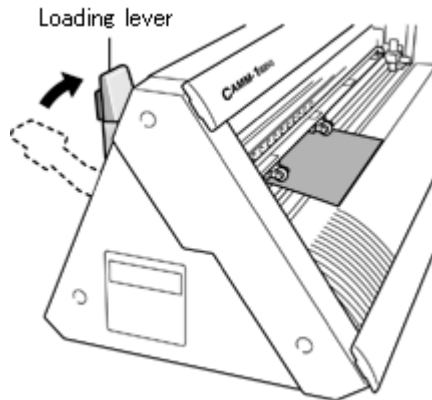

4. Turn on the GX-24 power.
5. Select **PIECE**.



6. Press **ENTER**.
7. Use the cursor keys to move the material and position the crop marks above the blade protector.  
\* If the bottom margin was set to 20 mm, the crop marks are positioned above the blade protector when the loading is complete.

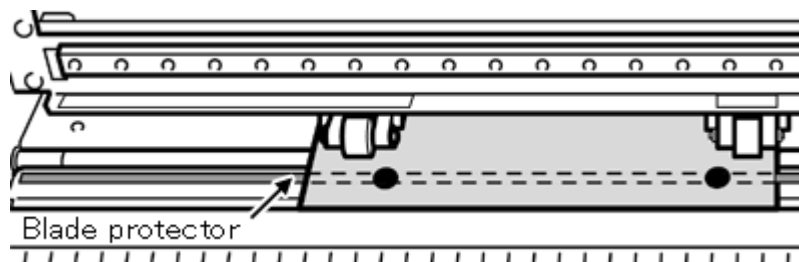

### Note

- Crop marks cannot be read in the cases indicated below. In such cases, remove the material once and load it again.
  - The left and right crop marks are slanted by 5 degrees or more with respect to the moving direction of the cutting carriage.
  - The crop marks are offset by 15 mm in the material-feed direction.

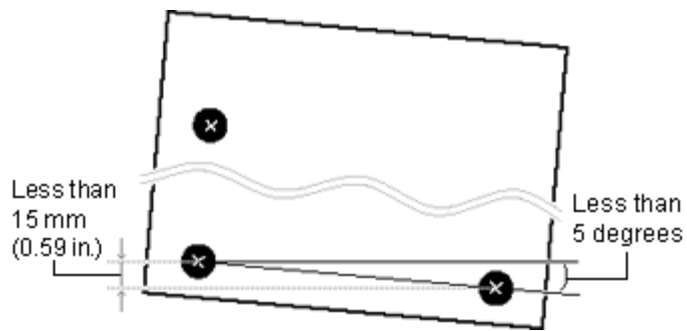

- The material sometimes curls when it is printed on the printer. Do not use a material that is curled as shown in the figure. The crop marks may not be read.

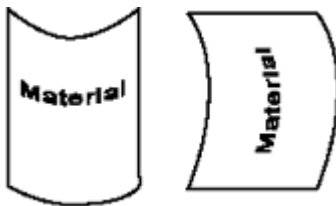

If this happens, straighten out the material before loading it on the GX-24.

- If the material has creases or wrinkles, stretch them out before loading the material. Crop marks may not be read if the material has creases or wrinkles. If the crop marks fail to be read, prepare a new material and repeat the operation from **Step2: Print the data**.

[\[Back/Next\]](#)

## Printing and Cutting (When Using CutStudio)

[\[Back/Next\]](#)

### Step 4: Perform cutting

1. Click  .  
The **Cutting** dialog box opens.
2. Check that **Name** is set to **Roland GX-24**, and click **OK**.  
The reading of the crop marks starts.  
When all three crop marks are read, cutting starts.

[\[Back/Next\]](#)

## Printing and Cutting (When Using Adobe Illustrator)

[\[Back/Next\]](#)

In this method, the data with crop marks is created on Illustrator and printed.

Then, the cutting data is sent to CutStudio, and cutting is performed on CutStudio.

Be sure to install CutStudio Plug-in for Adobe Illustrator before performing printing and cutting operations.

This section assumes that CutStudio Plug-in is already installed.

- [Step 1: Create the data](#)
- [Step 2: Print the data](#)
- [Step 3: Load the printed material](#)
- [Step 4: Perform cutting](#)

[\[Back/Next\]](#)

## Printing and Cutting (When Using Adobe Illustrator)

[\[Back/Next\]](#)

### Step 1: Create the data

1. Start **Illustrator** and open a new document.  
Set the art board.
2. From the **Window** menu, click **CutStudio Plug-in**.  
The **Roland CutStudio** palette opens.
3. Click  on the **Roland CutStudio** palette.  
Crop marks are inserted in the art board.

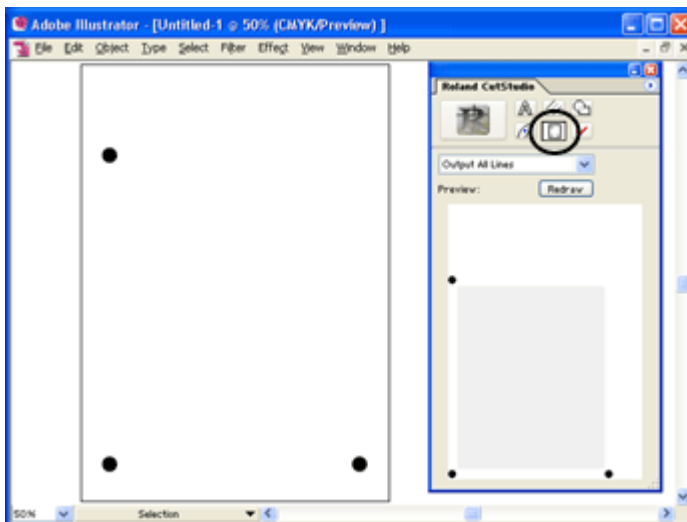

4. Click , and then click **Crop-mark Locations**.  
The **Crop-mark Locations** dialog box opens.

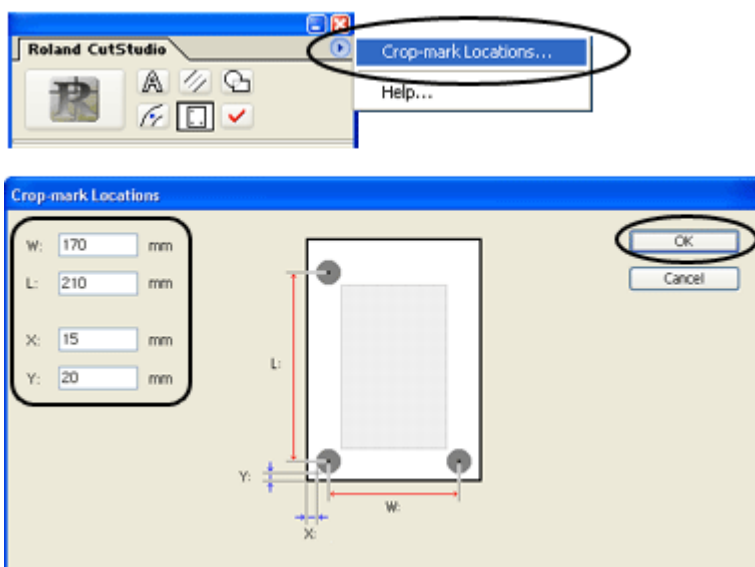

Set the crop mark positions according to the art board size, and then click **OK**.  
 When cutting with the GX-24, enter the following values.

Size	Crop mark positions
A4 portrait	X: 15 mm, Y: 20 mm L: 170 mm, W: 210 mm
A4 landscape	X: 30 mm, Y: 20 mm L: 240 mm, W: 120 mm
A3 portrait	X: 30 mm, Y: 20 mm L: 240 mm, W: 330 mm
A3 landscape	X: 15 mm, Y: 20 mm L: 380 mm, W: 205 mm
B4 portrait	X: 15 mm, Y: 20 mm L: 215 mm, W: 275 mm
B4 landscape	X: 15 mm, Y: 20 mm L: 325 mm, W: 170 mm

\* If you are using a material of size larger than A4 that is not listed above, set the values by referring to the figure below.

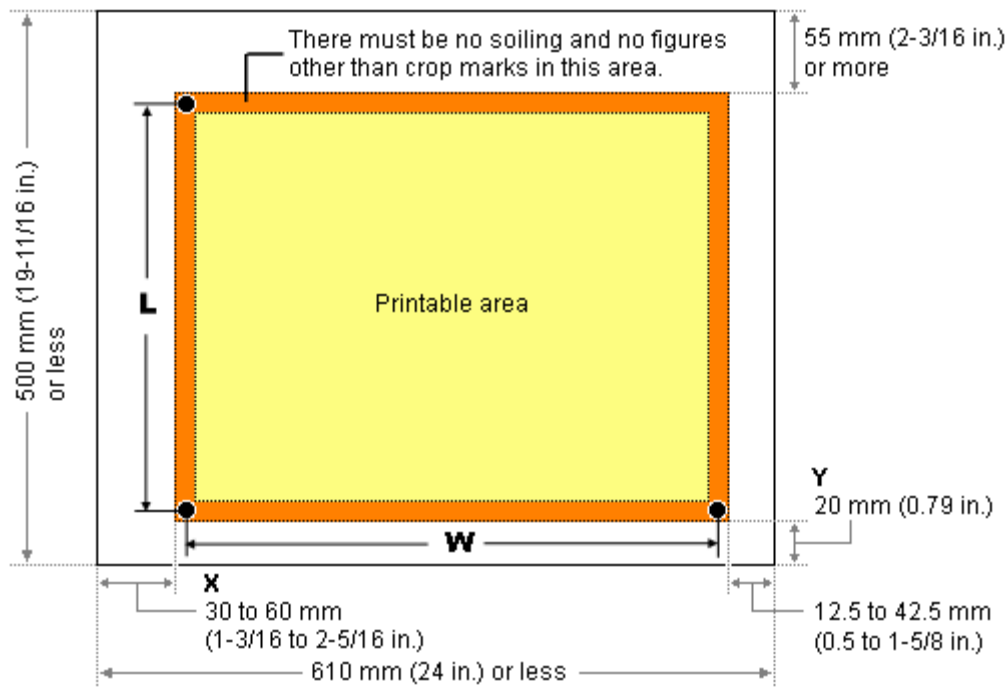

**Hint:** It is recommended that the Y value be set to 20 mm. It eliminates the hassle in loading the material.

**Reference:** [Load the printed material](#)

- Position the data in the area within the crop marks.

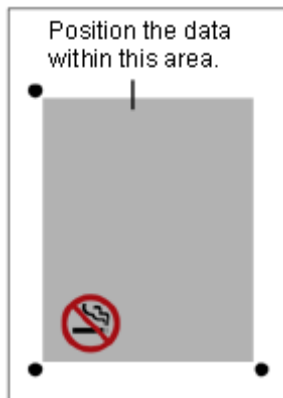

- Draw the cutting lines.
  - \* Create a new layer for the cutting lines and draw the cutting lines there.

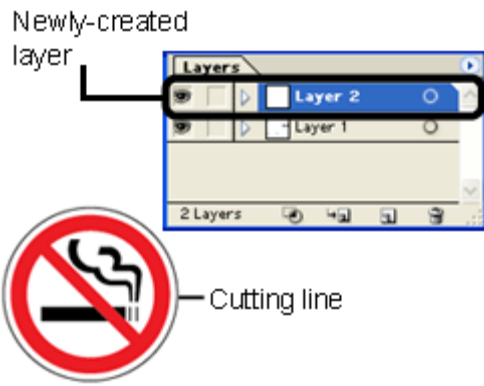

7. Save the data.

[\[Back/Next\]](#)

## Printing and Cutting (When Using Adobe Illustrator)

[\[Back/Next\]](#)

### Step 2: Print the data

1. Load the material to be cut in the printer.  
For details on how to load the material, see the instruction manual for your printer.
2. If you do not wish to print the cutting lines, hide the layer containing the cutting lines.

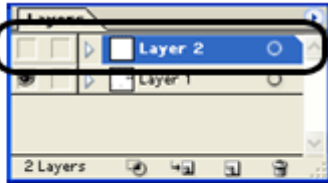

3. From the **File** menu, click **Print**.  
The **Print** dialog box opens.
4. Click **Print** (or **OK**).  
The image data with crop marks is printed.

#### Notes

If the layer containing the cutting lines is not hidden before executing the printing, the cutting lines are also printed.



[\[Back/Next\]](#)

## Printing and Cutting (When Using Adobe Illustrator)

[\[Back/Next\]](#)

### Step 3: Load the printed material

1. Pass the material through the machine and move the pinch rollers as shown in the figure.
  - Position the pinch rollers outside the crop marks.
  - Be sure that both edges of the material and the pinch rollers are inside the pinch-roller position-verification marks.

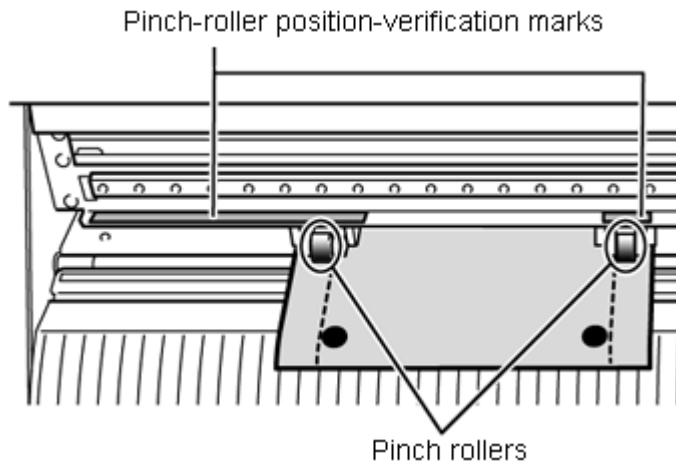

- Align the three crop marks as shown in the figure. If the material is loaded in the wrong direction, the GX-24 cannot read the crop marks.



2. Align the left edge of the material so that it lies parallel to the guide line.

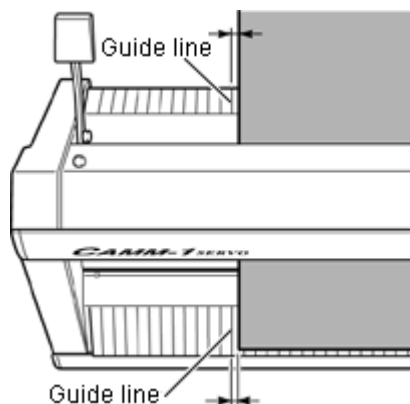

3. Raise the loading lever to secure the material in place.

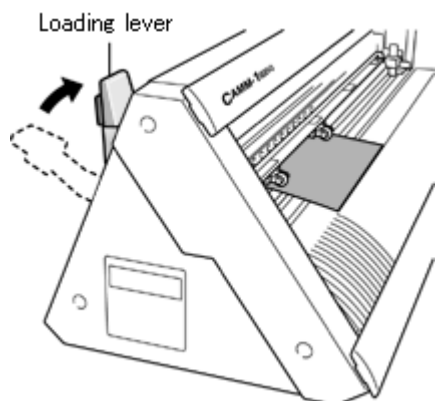

4. Turn on the GX-24 power.
5. Select **PIECE**.



6. Press **ENTER**.
7. Use the cursor keys to move the material and position the crop marks above the blade protector.  
\* If the bottom margin was set to 20 mm, the crop marks are positioned above the blade protector when the loading is complete.

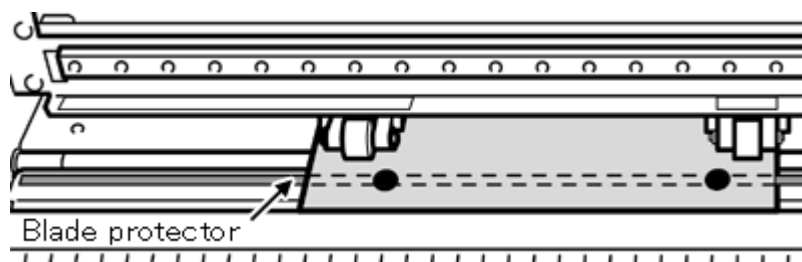

### Note

- Crop marks cannot be read in the cases indicated below. In such cases, remove the material once and load it again.
  - The left and right crop marks are slanted by 5 degrees or more with respect to the moving direction of the cutting carriage.
  - The crop marks are offset by 15 mm in the material-feed direction.

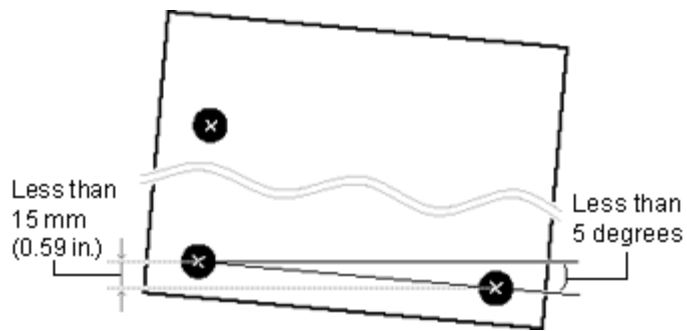

- The material sometimes curls when it is printed on the printer. Do not use a material that is curled as shown in the figure. The crop marks may not be read.

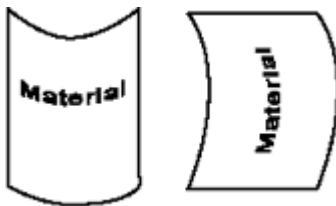

If this happens, straighten out the material before loading it on the GX-24.

- If the material has creases or wrinkles, stretch them out before loading the material. Crop marks may not be read if the material has creases or wrinkles. If the crop marks fail to be read, prepare a new material and repeat the operation from **Step2: Print the data**.

[\[Back/Next\]](#)

## Printing and Cutting (When Using Adobe Illustrator)

[\[Back/Next\]](#)

### Step 4: Perform cutting

1. Show the layer containing the cutting lines and select it.

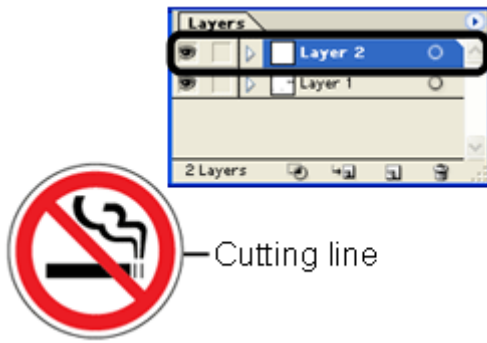

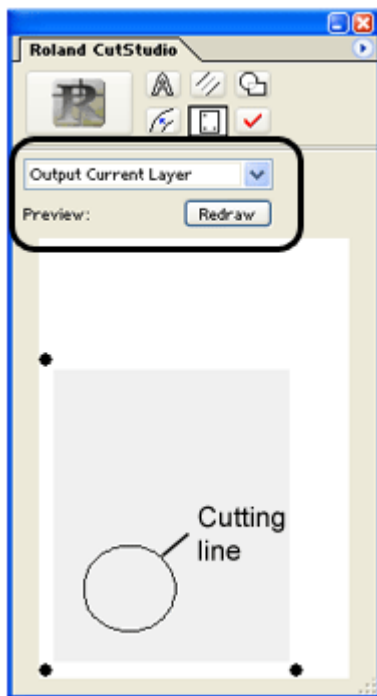

2. On the **Roland CutStudio** palette select **Output Current Layer**, and then click **Redraw**.

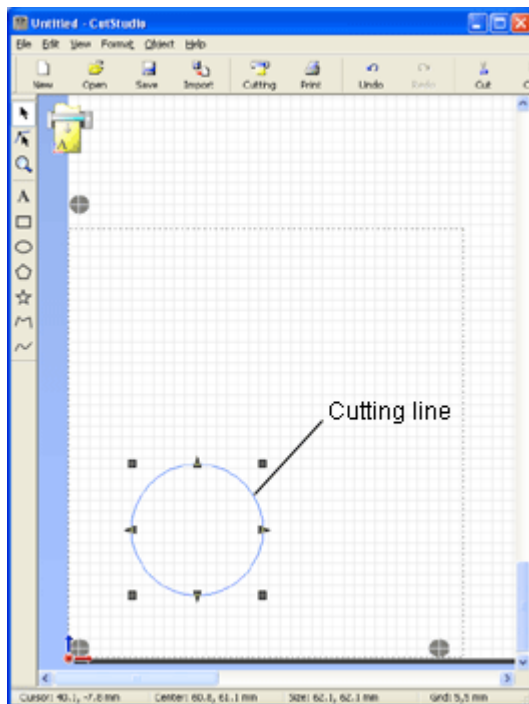

Check that all the cutting lines that you wish to cut are shown on the preview screen.

3. Click .  
CutStudio starts, and the cutting data is sent to CutStudio.



4. Click  on CutStudio.  
The **Cutting** dialog box opens.
5. Click **OK**.  
The reading of the crop marks starts.  
When all three crop marks are read, cutting starts.

[\[Back/Next\]](#)

## What to Do If

[\[Back/Next\]](#)

This section explains problems related to the printing and cutting operations and their solutions. For details on other types of problems (such as GX-24 fails to run, uncut areas remain, and cut edges cannot be cut cleanly), see [What to Do If](#) in the **GX-24 Reference Guide (electronic format manual)**.

- [The printing and cutting positions are offset.](#)
- [Crop marks cannot be read.](#)
- [When using a software other than the included software.](#)

[\[Back/Next\]](#)

## What to Do If

[\[Back/Next\]](#)

### The printing and cutting positions are offset.

If the printing and cutting positions are offset, this may be because the printing positions of the crop marks are offset.

If this is the case, adjust the positions as follows. However, if the offset is too large, the GX-24 may not be able to read the crop marks. If this happens, redo the work from the beginning.

1. From the **File** menu, click **Printing Setup** .  
The **Printing Setup** dialog box opens.
2. Select the **Fine adjustment** check box, and then click **Adjust**.  
The **Crop Mark Adjustment** dialog box opens.

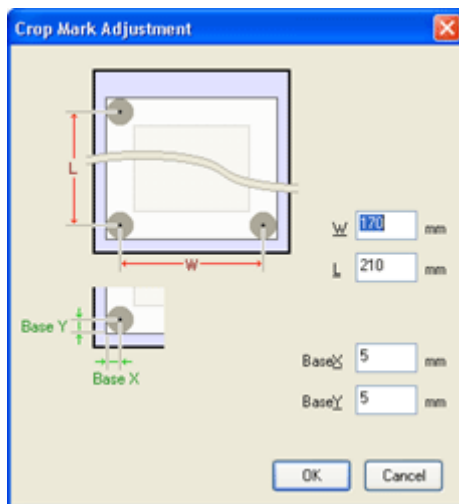

3. Align the position with respect to a line or point that is close to the origin. Adjust the **Base X** and **Base Y** values to eliminate the offset, and then click **OK**. Do not change the **W** and **L** values at this point.

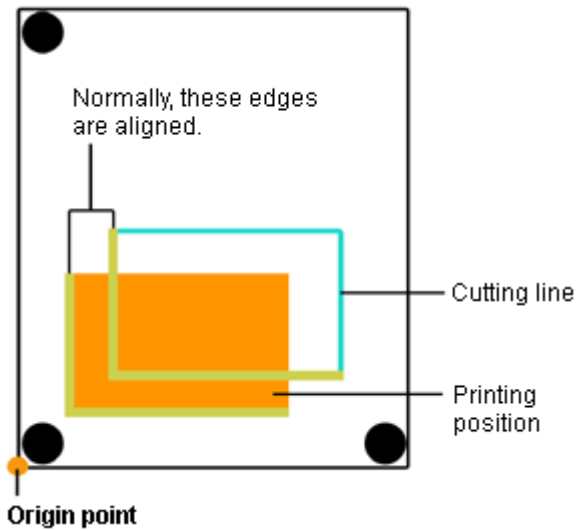

- The cutting position is offset to the left or right of the printing position. Change the **Base X** value. If the cutting position is offset to the right, increase the value; if it is offset to the left, decrease the value. In the case shown in the figure above, increase **Base X**
- The cutting position is offset above or below the printing position. Change the **Base Y** value. If the cutting position is offset above, increase the value; if it is offset below, decrease the value. In the case shown in the figure above, increase **Base Y**

If the printing and cutting positions are offset at a location distant from the origin as shown in the figure below even after adjusting the positions with **Base X** and **Base Y** values, it is possible that the distance between the crop marks that are printed is offset from the settings (**W** and **L**). This may be due to the expansion or contraction of the material or distortion in the printing. Proceed to step 4.

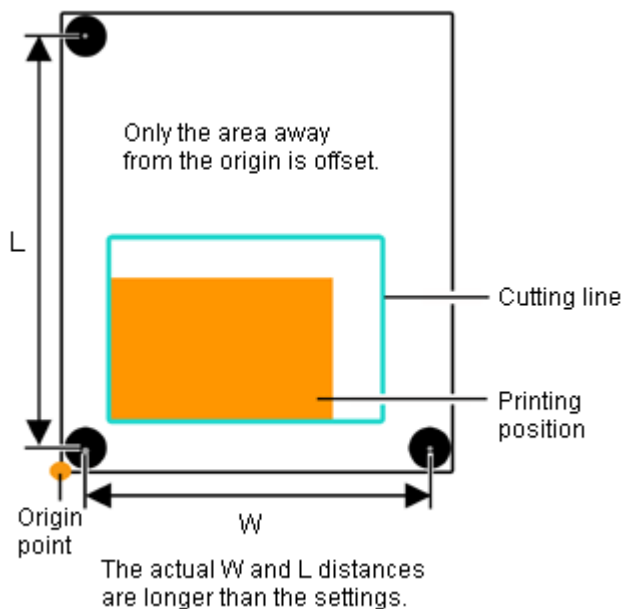

- Set **W** and **L** in the **Crop Mark Adjustment** dialog box as described below to correct the error. However, the values are merely guide lines. The optimal values must be found by changing the values and actually cutting the material several times.

### Notes

Before changing the settings, check that the **Base X** and **Base Y** settings have been adjusted with respect to a line or point close to the origin. If they were not, the adjustment result of step 3 will be offset if the **W** and **L** settings are changed.

- The cutting lines are offset outward from the printing position.

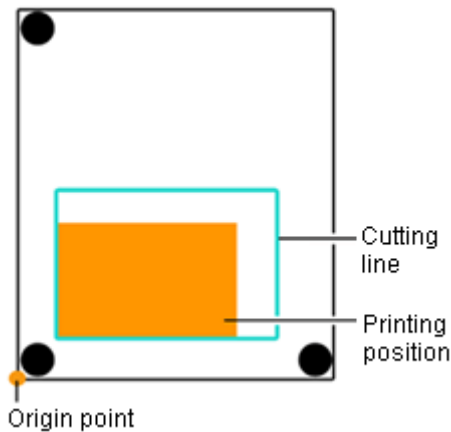

This may be because the distance between the printed crop marks is longer than the setting. In this case, set the **W** and **L** values greater than the settings to make the adjustment.

- The cutting lines are offset inward from the printing position.

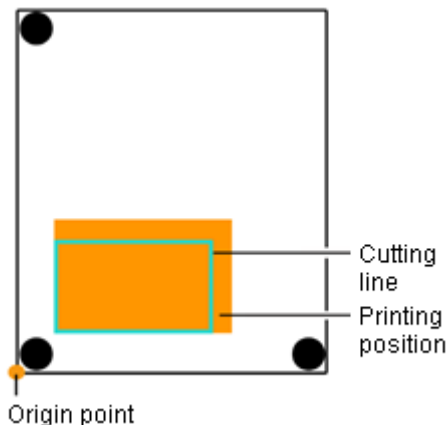

This may be because the distance between the printed crop marks is shorter than the setting. In this case, set the **W** and **L** values smaller than the settings to make the adjustment.

### Notes

The values entered in the **Crop Mark Adjustment** dialog box are effective only when **Fine adjustment** in the **Printing Setup** dialog box is enabled. All the entered values are cleared if **Fine adjustment** is disabled or if the **W** and **L** values of **Crop marks** are changed.

## What to Do If

[\[Back/Next\]](#)

### **Crop marks cannot be read.**

Check the following items.

- **Is the material loaded properly?**

Refer to [Load the printed material](#) and load the material correctly.

- **Is the loaded material curled upward?**

Straighten out the material before loading.

- **Does the material have creases or wrinkles?**

Crop marks may not be read if the material has creases or wrinkles.

Stretch the creases or wrinkles out and load the material again. If the crop marks still fail to be read, prepare a new material and repeat the operation from **Step2: Print the data**.

#### [When using CutStudio](#)

#### [When using Illustrator](#)

- **Are you using a material that is not white or that has decorations?**

Crop marks cannot be detected if decorations or colors are on the material.

Crop marks also cannot be detected on glossy or laminated material even if it is white.

- **Are the crop marks blurred or are they printed using a color other than black?**

Set the color of crop marks to black, specify 100% density, and print the data again.

- **Are the size and shape of crop marks correct?**

Make the crop marks perfect circles with 10-mm diameter.

For details, see [Printing and Cutting Overview](#).

Crop marks that are printed using dedicated crop mark generation functions of the software cannot be detected.

- **Are the crop marks at the correct positions?**

Refer to **Create the data** and place the crop marks at the correct positions.

### When using CutStudio

### When using Illustrator

Do not expand or reduce the data when printing. If you do, the printed positions of the crop marks will be offset.

- **Are the settings for the driver correct?**

Check the settings according to the following procedure.

1. From the **File** menu, click **Cutting Setup**. Check that the printer name is **Roland GX-24**, and then click **Properties**.
2. Click the **Size** tab and check that **Rotate** is set to **Off**.  
If **90 deg** is specified, the GX-24 cannot detect the crop marks.

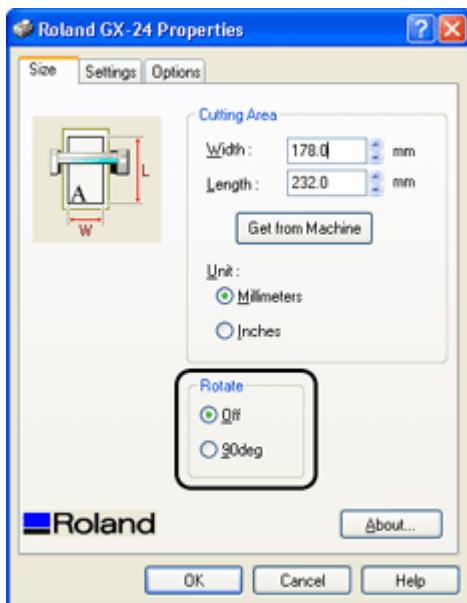

- **Are the settings for the GX-24 correct?**

Check that the **ROTATE** menu is set to **0deg**. If set to **90deg**, set it to **0deg**. For the verification and setup procedure see [here](#).

- **Is direct sunlight or high intensity indoor light hitting the machine?**

If direct sunlight or indoor light hits the cutting carriage sensor, crop marks may not be detected. Move the machine to a location where direct sunlight or indoor light does not hit the machine.

[[Back](#)/[Next](#)]

## What to Do If

[\[Back\]](#)

### **When using a software other than the included software**

To use crop marks, you must manually make the machine read the crop marks. Refer to "**Cutting by Manually Aligning the Position**" in the "**GX-24 Reference Guide**" (**electronic format manual**) and manually set the crop mark positions. For details, see [here](#).

[\[Back\]](#)